

**Basic Instructions only!**  
For more detailed product information, refer to the  
StageTek Staging System Owner's Manual 280A099.

### **⚠ CAUTION**

*Make sure anyone assembling or installing StageTek components has read and understands the instructions.*

### **⚠ CAUTION**

*Always comply with Warnings or Cautions in the instructions or posted on the equipment.*

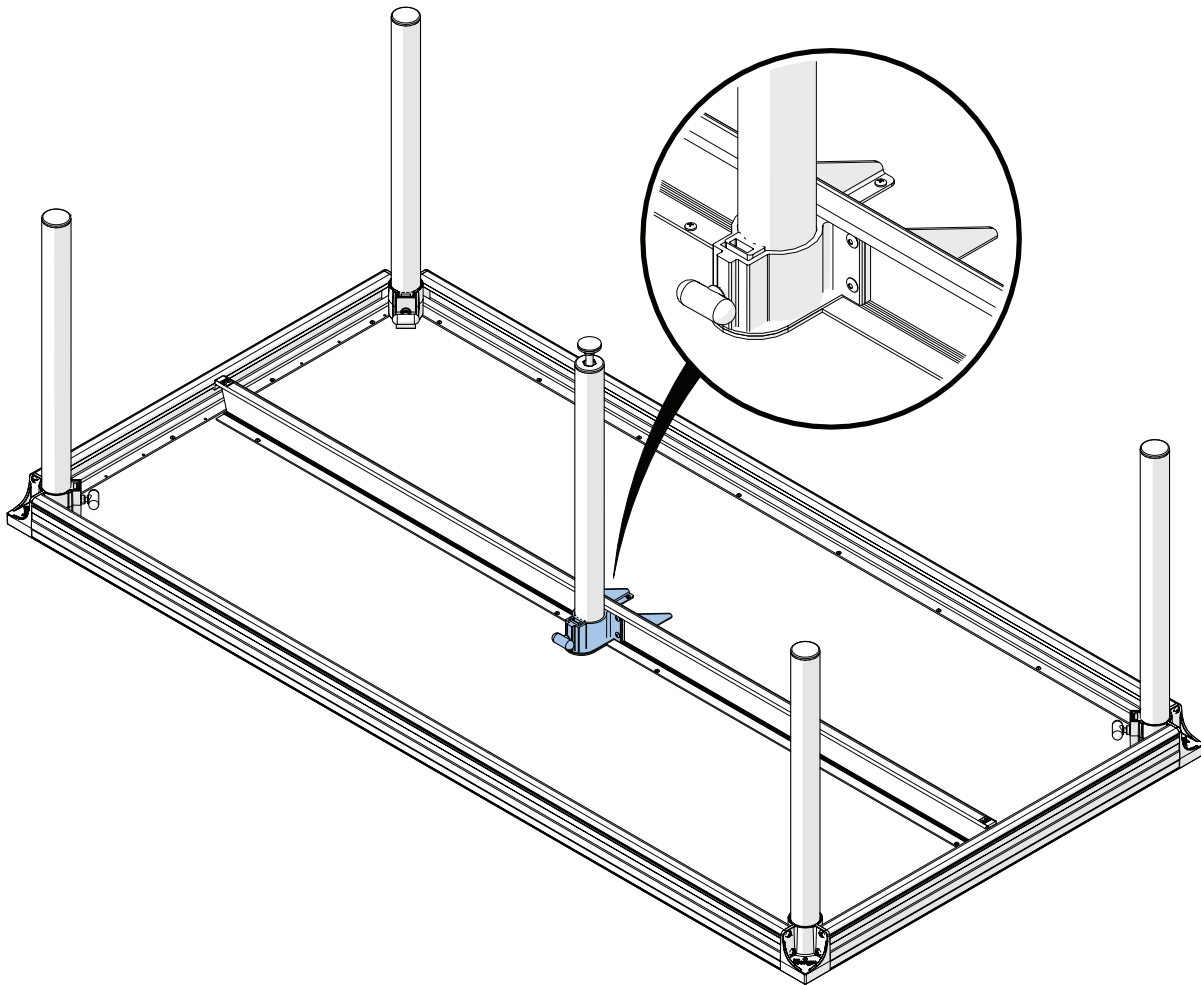

Visit the StageTek Staging System web page at [wengercorp.com](http://wengercorp.com) for more information.

**Note:** Please read and understand these instructions before assembling or setting up.

**Note:** If you need additional information, contact Wenger Corporation using the information below.

1. On the underside of the platform deck, measure along the center rail to find the center and mark the location as shown.

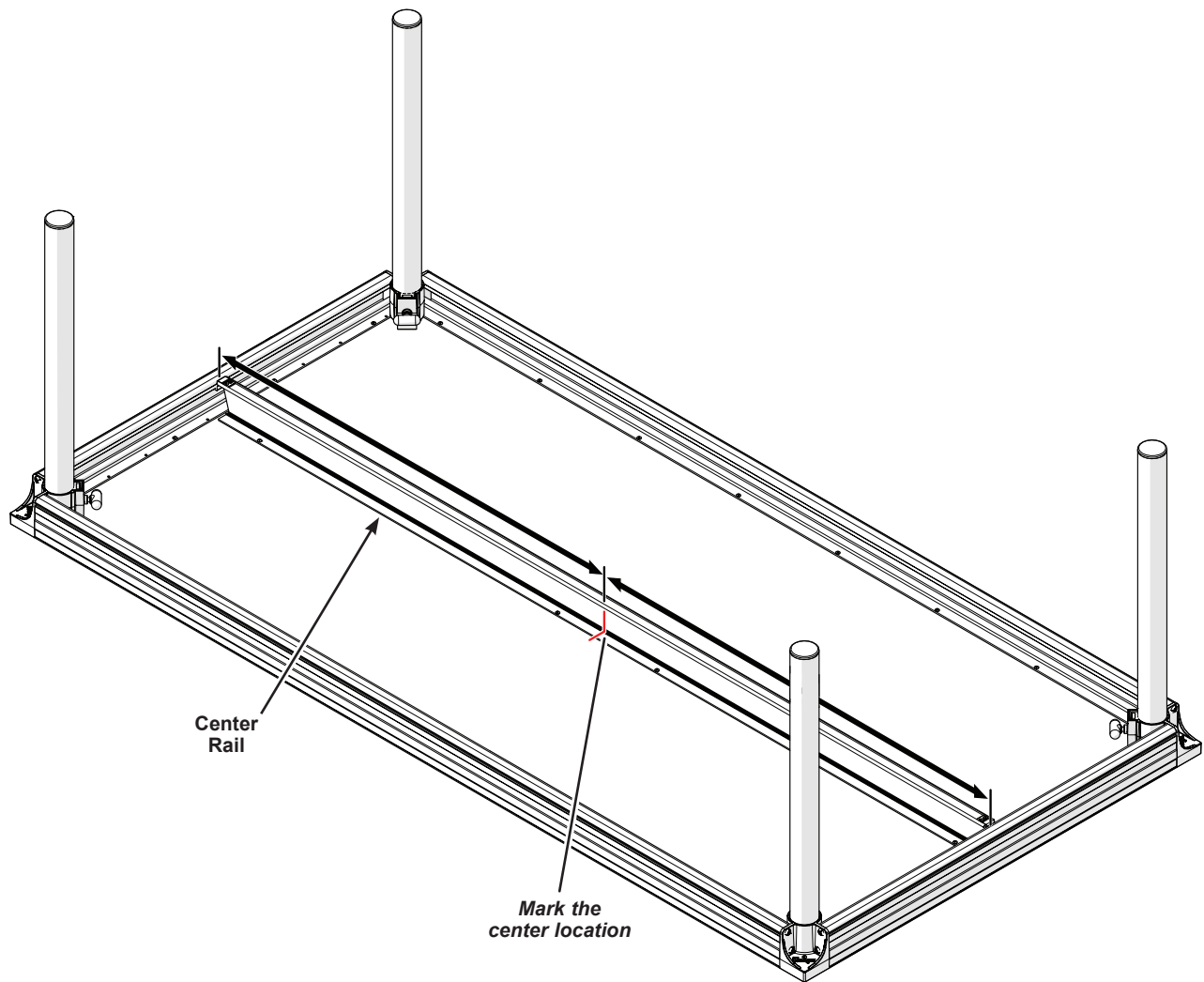

2. Place the center leg bottom spacer plate flat on the deck surface to be flush with the edge of the center rail and centered on the center mark as shown.
3. Place the center leg top plate directly on top of the center leg bottom plate, aligning the pilot holes.
4. Secure the center leg bottom plate and the center top plate to the deck surface using two #10-16 x 3/4" pan head screws.

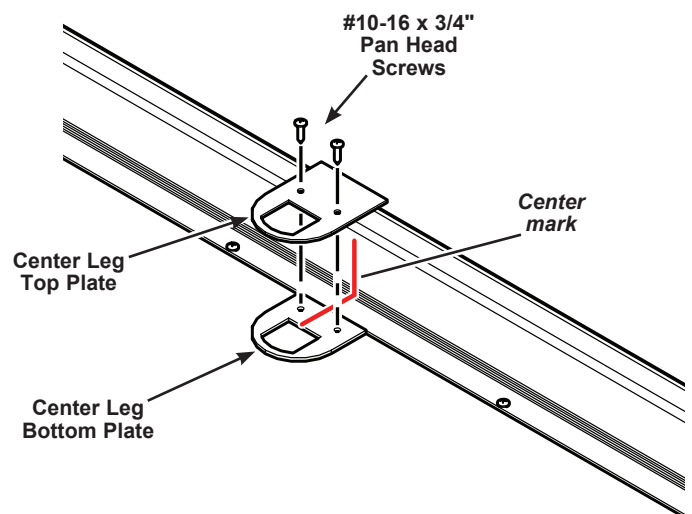

- Place the center leg spacer flush against the center rail and centered over the center mark as shown.

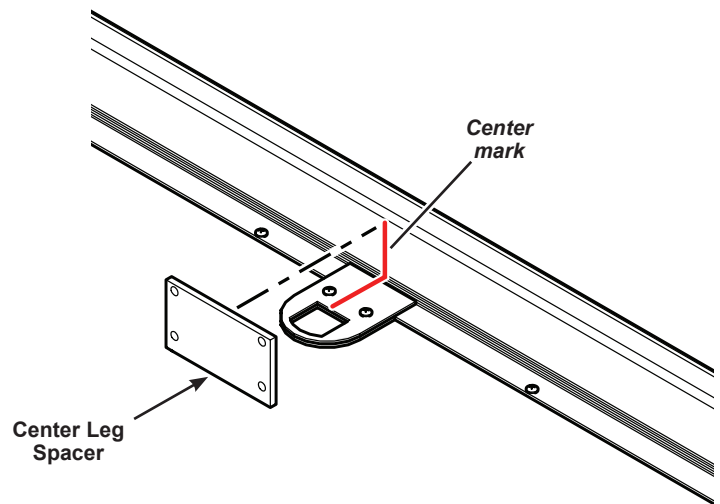

- Tilt the straight corner pocket assembly to fit the bottom of the shoe into the square hole of the center leg bottom plate. Then tip it down to align the with the pilot holes in the center leg spacer as shown.

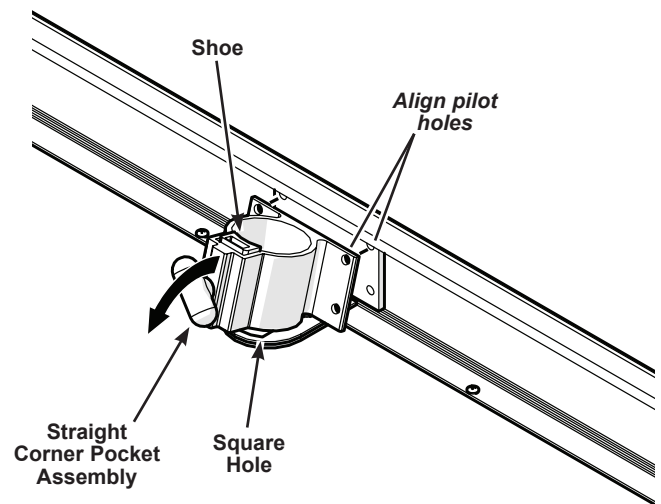

- Using the aligned sets of pilot holes in the straight corner pocket assembly and center leg spacer as a guide, drill four 1/4" (6 mm) holes straight through the center rail.

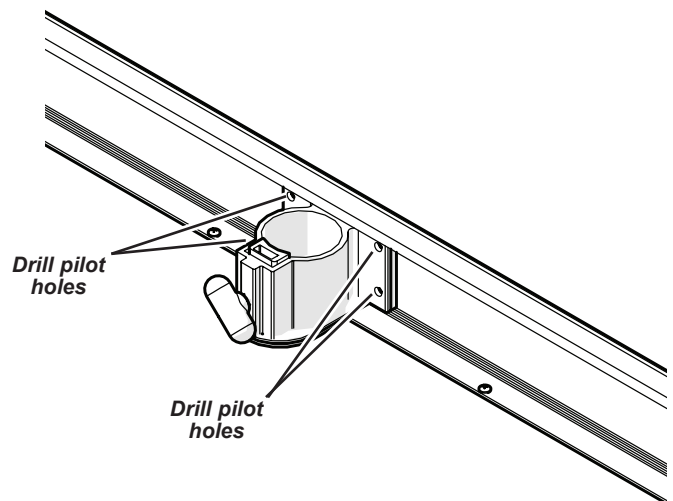

8. With the flange side facing the platform deck, align the pilot holes in the center leg bracket with the holes that were just drilled in the center rail. Attach these components together using four 1/4-20 x 1" capscrews and 1/4-20 lock nuts as shown.

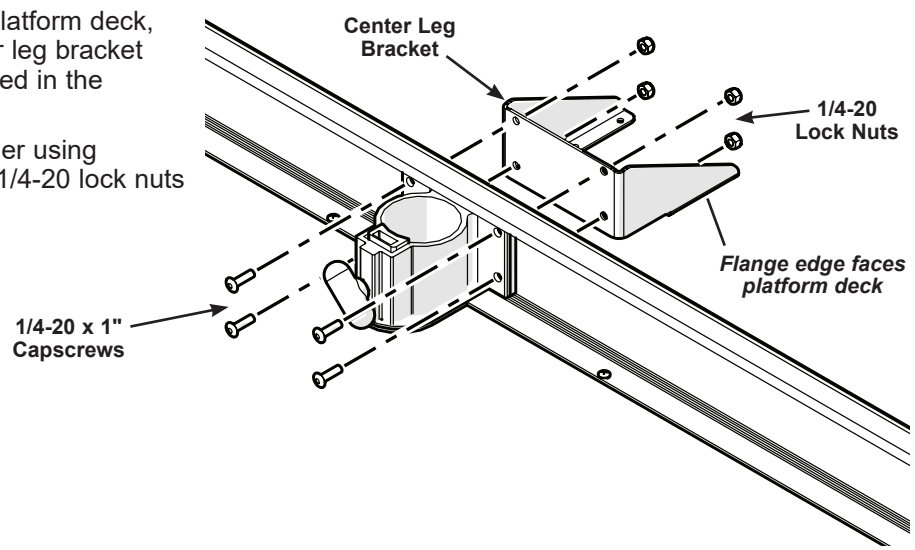

9. Attach the center leg bracket to the platform deck surface using four #10-16 x 3/4" pan head screws through the pilot holes.

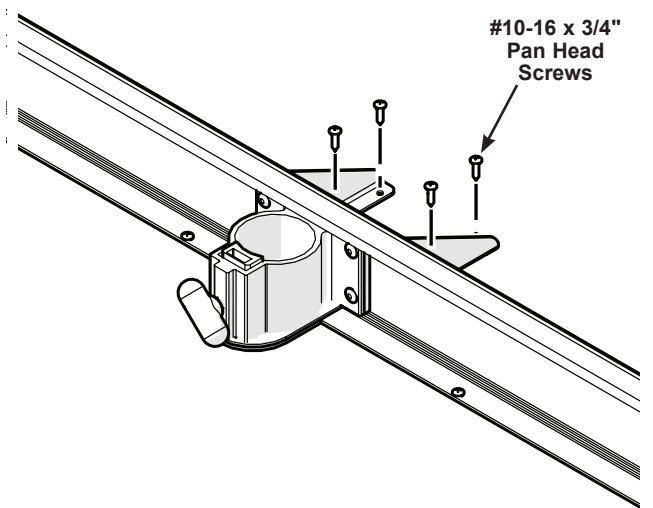

10. Insert, attach and secure a leg into the pocket assembly using the same procedure as the other legs.

